

# Technical Datasheet GSD200





## COMPONENT LIST

Side view of guide rail and hanger

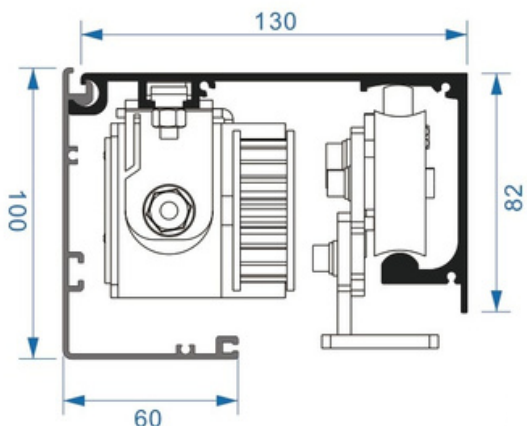

		
Cover plate	Track	Hanger
		
Motor	Controller	Sensor
		
Belt	Pulley	Glass clamp & Floor guides

## Technical Details

<b>Model</b>	<b>GSD200</b>
<b>Single leaf</b> <ul style="list-style-type: none"> <li>• Door Leaf Weight</li> <li>• Door leaf width</li> <li>• Width of door opening</li> <li>• Manual thrust</li> </ul>	Max.200kg DW=400-3000mm W=400-3000mm <40N
<b>Double leaf</b> <ul style="list-style-type: none"> <li>• Door Leaf Weight</li> <li>• Door leaf width</li> <li>• Width of door opening</li> <li>• Manual thrust</li> </ul>	Max.180kg DW=400-3000mm W=400-3000mm <50N
Installation Method	Surface installation
Power voltage	AC 110-250V ,50Hz
Power consumption	70W
Opening speed	15-50cm/s (adjustable)
Closing speed	13-50cm/s (adjustable)
Door-hold open time	0-20s (adjustable)
Class of protection (IP Rating)	IP44
Working environment temperature	-20 °C- + 50 °C