

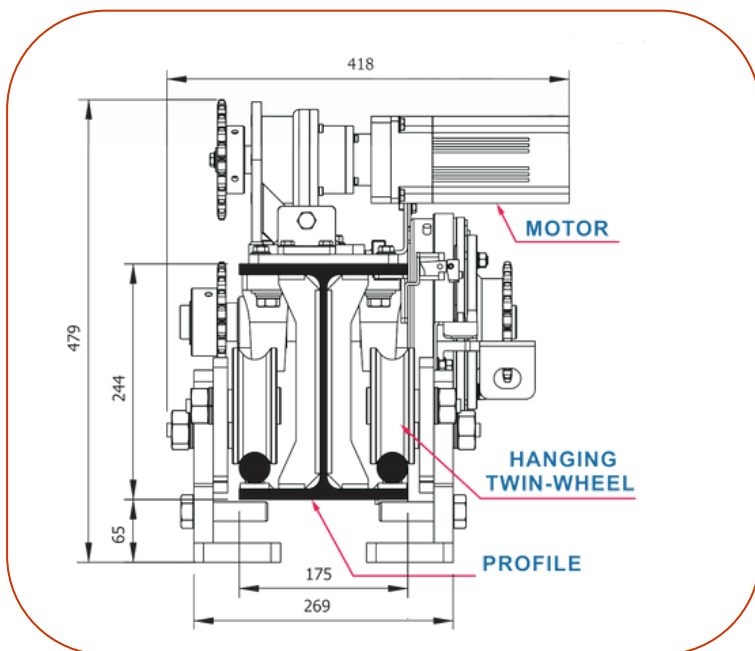

Technical Datasheet

GSH10000

Positions of all components in the guide rail

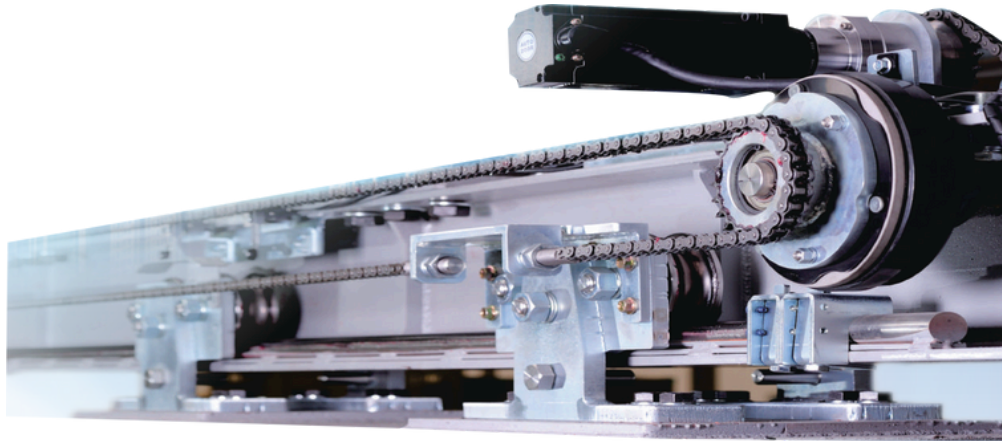

Technical Details

Door Weight : 10000 kg X 1 (Door) / 8000KG X 2

Door Width : 1M-6M

Profile Type : H-Type Steel/Single Track

Motor : DC320V 370W BRUSHLESS DC MOTOR
(Planetary Gear)

Transmission : Electromagnetic Bearing-Mounted Clutch

Control : Standard Micro-Control

Power Consumption : 370 W

Voltage : AC220

Environmental Temperature : -20°C~50°C

Volume : 65 Decibel (Max)

Starting Speed : 230mm/Sec. / 200mm/Sec.

Starting Time : 0~20 Sec. (Regulable)

Transmission Important Condition : Roller Chain 50-1R

Opening Door Range : FULL/Half-Open (Regulable)

Material of Hanger : Stainless 304

Bearing : Roller Bearing

Second System : None/Including

COMPONENT LIST

